

PIPER ROBOTIC ARM

Quick start user manual v1.0

2024.09



AGILE·X

Important Safety Information

This chapter contains important safety information. Any individual or organization must read and understand this information before using the device, especially before powering it on for the first time. It is crucial to follow and comply with all assembly instructions and guidelines in this manual. Pay special attention to the text related to warning signs. Before using the device, be sure to obtain and read the "PiPER User Manual." If you have any questions about usage, feel free to contact us at support@agilex.ai.

Warning icon : ⚠ This refers to situations that may pose a danger, which, if not avoided, could lead to personal injury, property damage, and severe equipment damage.

Warning ⚠ : Songling Robot Co., Limited (Brand name: AgileX Robotics. Hereinafter referred to as AgileX Robotics.) will not be held responsible if the robotic arm is damaged, altered or modified in any way. AgileX Robotics will not be held responsible for any damage to the robotic arm or any other equipment caused by programming errors or operating failures.

Limitation of Liability: Once the robotic arm is put into use, it is considered that you have read, understood, acknowledged, and accepted all the terms and contents of this product's user manual and safety information. The user commits to being responsible for their own actions and all consequences arising from them. The user agrees to use the robotic arm only for legitimate purposes and accepts these terms, as well as any relevant policies or guidelines that AgileX Robotics may establish. During the use of the robotic arm, please strictly comply with and follow the requirements outlined in, but not limited to, the user manual and safety information. AgileX Robotics will not be liable for any personal injury, accidents, property damage, legal disputes, or conflicts of interest resulting from improper use or force majeure. The robotic arm is not suitable for individuals under the age of 18 or those lacking full civil capacity. Please ensure such individuals do not come into contact with this product, and take extra precautions when operating the device in their presence.

The information in this manual does not cover the design, installation, and operation of a complete robotic arm application, nor does it include all possible peripheral equipment that may impact the safety of the entire system. The design and use of the complete system must comply with the safety requirements established by the standards and regulations of the country where the robotic arm is installed.

It is the responsibility of the robotic arm integrator and the end customer to ensure compliance with the relevant regulations and applicable laws, ensuring that no significant hazards exist in the complete robotic arm application. This includes, but is not limited to, the following:

1. **Effectiveness and Responsibility**
 - Conduct a risk assessment for the complete robotic arm system.
 - Connect additional safety devices for other machinery as defined in the risk assessment.
 - Ensure the accurate design and installation of the entire robotic arm system, including both software and hardware.
 - The integrator and end customer must follow relevant regulations and applicable legal requirements for safety assessment to ensure that the developed robotic arm has no major hazards or safety risks in actual applications.
 - Be aware of any potential safety risks before operating and using the equipment.
 - Ensure that users do not modify any safety measures.
 - Collect all documents in the technical files, including the risk assessment and this manual.
2. **Environment**
 - Before first use, carefully read this manual to understand basic operations and usage guidelines.
 - Choose a relatively open area for use, as the robotic arm does not come with any automatic obstacle-avoidance or sensing sensors.
 - Use the robotic arm in an environment with a temperature between -20°C and 50°C.
 - If the robotic arm is not custom-made with a specific IP protection rating, its water and dust resistance is rated at IP22.
3. **Check**
 - Ensure the robotic arm has no visible abnormalities.
 - Ensure proper connection of the wiring harness during use.
4. **Operation**
 - Ensure the surrounding area is relatively open during operation.
 - Operate within visual range.
 - The maximum payload of the robotic arm is 1.5KG; ensure that the effective load does not exceed 1.5KG during use.
 - If the equipment shows abnormalities, stop using it immediately to avoid secondary damage.
 - If abnormalities occur, contact relevant technical personnel and do not handle it on your own.
 - Use the equipment in an environment that meets the IP protection rating requirements.

5. Warnings⚠ :

- Ensure that the robotic arm and tools/end effectors are always correctly and securely fixed in place.
- If you must enter the robotic arm's working space, wear safety goggles and protective equipment to protect yourself.
- Ensure that the robotic arm has enough space for free movement.
- Ensure that safety measures are established as defined in the risk assessment.
- Do not wear loose clothing while operating the robotic arm. Tie back long hair when operating the robotic arm.
- Do not use the robotic arm if it is damaged or showing any abnormalities.
- If the host computer software displays error messages, immediately perform an emergency stop and contact relevant technical personnel.
- Ensure that people keep their heads, faces, or other body parts away from the operating robotic arm or from the area the robotic arm can reach during operation.
- Never modify the robotic arm. Altering the robotic arm may introduce unforeseen dangers for the integrator.
- Do not expose the robotic arm to permanent magnetic fields. Strong magnetic fields can damage the robotic arm.
- The robotic arm generates heat during operation. Do not handle or touch the robotic arm while it is operating or shortly after it has stopped, as prolonged contact may cause discomfort. Power off the system and wait for one hour for the robotic arm to cool down.
- Connecting different machines together may increase risk or introduce new hazards. Always perform a comprehensive risk assessment for the entire installation. Depending on the risk assessment, different functional safety levels may apply; therefore, when different safety and emergency stop performance levels are required, always choose the highest performance level. Always read and understand the manuals for all devices used in the installation.
- The robotic arm is not suitable for use by individuals under the age of 18 or those who do not possess full civil capacity.

Table of Contents

1. Introduction	- 4 -
1.1. Packing List	- 4 -
2. Basic Usage	- 4 -
2.1. Electrical Interface Introduction	- 5 -
2.1.1 Robotic Arm Electrical Panel Instructions	- 5 -
2.1.2 Aviation plug Instructions	- 5 -
2.1.3 CAN connection	- 6 -
2.2. Robotic Arm Teach/Demonstration Mode Instructions	- 6 -
2.3. Base Installation Instructions	- 7 -
2.4. End Part Installation Instructions	- 8 -
3. ArmRobotUA Host Computer Usage Instructions	- 8 -
4. Secondary Development	- 10 -
5. Technical Specifications	- 10 -

1. Introduction

This 6 DOFs robotic arm is specifically designed for the education and research industry, consumer-level applications, and industrial automation. With a payload capacity of 1.5kg, it is suitable for various research and industrial applications, including humanoid robots, automatic assembly, and automated handling. The six rotating joints provide full-range operational flexibility, ensuring high precision and repeatability. The robotic arm features a modular design, making it easy to maintain and upgrade. It offers an intuitive user interface that simplifies programming and operation, allowing even non-professionals to get started quickly. It can be widely applied in fields such as scientific research, education, automotive manufacturing, electronics assembly, food processing, laboratory automation, and medical equipment operation.

1.1. Packing List

Name	Quantity
6 DOFs Robotic arm	1
USB toCAN module	1
Power adapter	1
MicroUSB cable	1
Power and communication cable	1
Base mounting screws	4
Base installation wrench	1

2. Basic Usage

The robotic arm has 6 DOFs and a 1.5kg payload at the end. The six rotating joints provide full-range operational flexibility, ensuring high precision and repeatability. It features a lightweight design, allowing the robotic arm to achieve fast motion capabilities while maintaining a relatively high payload capacity. It can be widely used in embodied intelligence for real-world data collection.

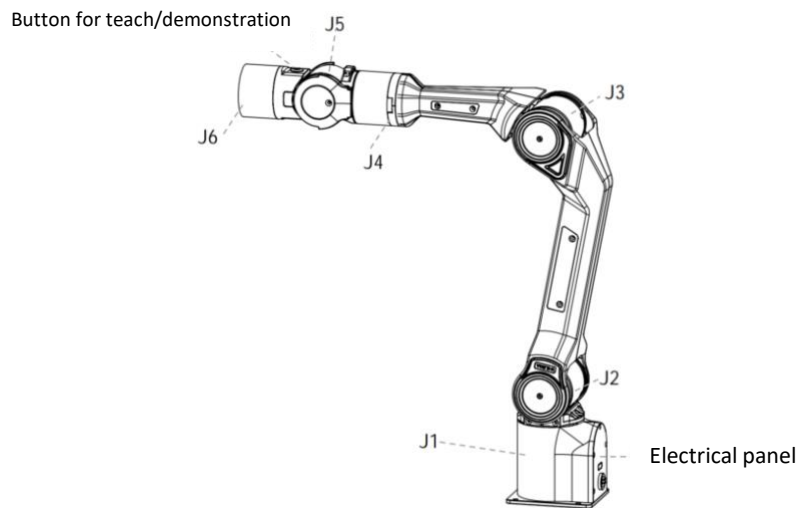

2.1. Electrical Interface Introduction

2.1.1 Robotic Arm Electrical Panel Instructions

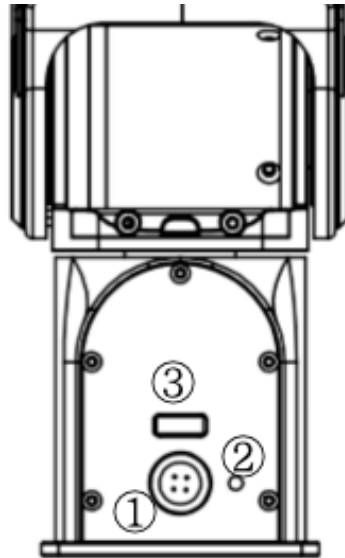

- 1: Power and communication port
- 2: Status Indicator Light
- 3: J1 & J2 connection port

2.1.2 Aviation plug Instructions

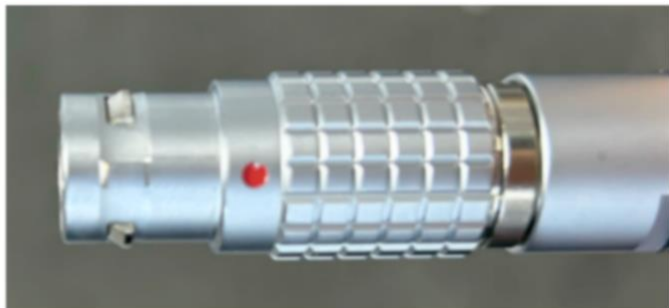

- 1: Power and communication port
- 2: Status indicator light
- 3: J1J2 connection port
- 4: Power positive
- 5: Power negative
- 6: CAN-H
- 7: CAN-L

Note: Align the red dot with the corresponding red dot on the cable. The textured area of the connector is designed to retract under force. During installation, align the red dot downward with the protruding point and insert it directly. To remove, press down on the textured area and pull it out.

2.1.3 CAN connection

CAN Connection and Preparation

Lead out the CAN cable and connect the CAN_H and CAN_L wires to the CAN_TO_USB adapter.

Connect the CAN_TO_USB adapter to the laptop's USB port. The connection diagram is shown in Figure 3.4.

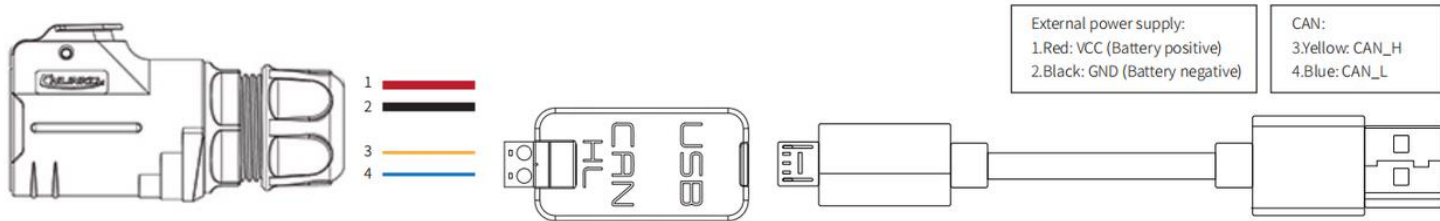

Note: If using a non-standard charger, the power input must not exceed 26V, and the current must be no less than 10A.

2.2. Robotic Arm Teach/Demonstration Mode Instructions

The robotic arm's drag & teach mode status is indicated by the button light between J5 and J6.

There are three types of robotic arm status light displays:

1. **No light display:** Robotic arm's drag & teach mode is stopped, or the drag recording has ended.

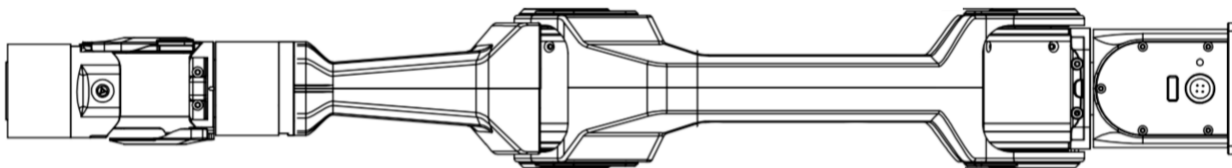

2. **Solid green light:** The robotic arm has entered the drag & teach mode for trajectory recording.

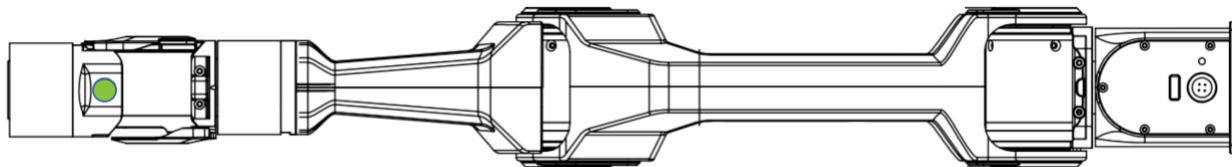

3. **Flashing green light:** The robotic arm has entered the drag & teach mode for trajectory playback.

How to switch to drag mode:

1. **Single click button:** Toggle between drag teach trajectory recording and stopping the drag recording.
2. **Double click button:** Activates the drag teach trajectory playback mode.

Instructions:

First, observe the indicator light status:

1. If the light is off, click the button once. The green light should turn solid, indicating that the user can drag the robotic arm to start recording the trajectory.

2. If the light is off and a trajectory has been recorded previously, double-click the button. The green light should flash every 500ms, indicating the robotic arm is in playback mode and will reproduce the recorded trajectory.
3. If the light is solid, it indicates trajectory recording is in progress. To stop the recording, click the button once; the light should turn off, indicating that recording has ended. If you want to replay the trajectory, follow step 2.
4. If the light is flashing, the robotic arm is currently in playback mode.

Notes:

1. During trajectory playback, the user must keep a safe distance from the robotic arm to avoid injury.
2. Each time the robotic arm enters teach trajectory recording mode, the previously recorded trajectory is erased. The playback mode will use the most recent recorded trajectory.
3. The maximum trajectory recording time is 3 minutes; any trajectory exceeding this time will be invalid.
4. After finishing drag teaching, ensure the indicator light is off/drag teaching mode is stopped.
5. If you want to switch to host computer control or command control, ensure the indicator light is off/drag teach mode is stopped. Then switch to standby mode via the host computer, and after entering standby mode, switch to CAN mode. The same applies to command control—first switch to standby mode, then switch to CAN control mode.

Note: When switching from link mode and teach by dragging mode to CAN control mode, the robotic arm must be positioned at the zero point before changing modes. The zero point is shown in the figure below:

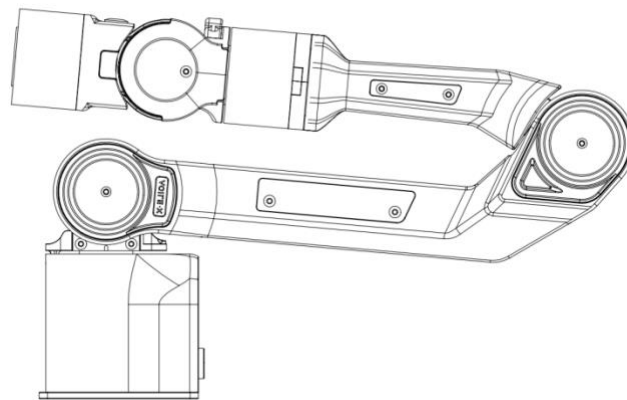

Robotic Arm Zero Point

2.3. Base Installation Instructions

The robotic arm base is installed using screws for fixation. The base has four pre-drilled M5 threaded holes. The accessory kit includes four M5 screws, which can be tightened using the provided hex tool. The hole spacing is 70mm. If you need to attach the base to mobile equipment or a fixed surface, you can design the corresponding structure with 70mm hole spacing.

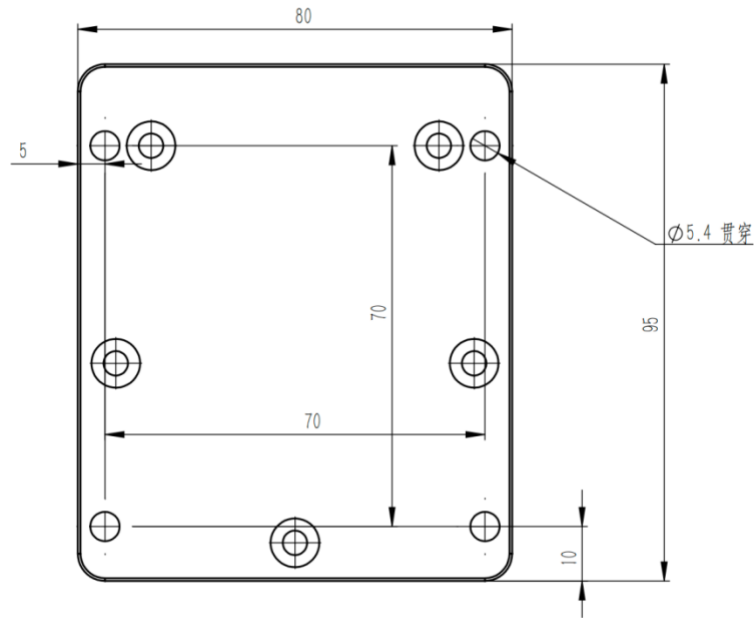

2.4. End Part Installation Instructions

The end can be equipped with other tools via a flange. Optional accessories include a two-finger gripper and a teach pendant. The installation method is shown in the diagram below. Details of the two-finger gripper and teaching device parameters can be found in the technical specifications at the end.

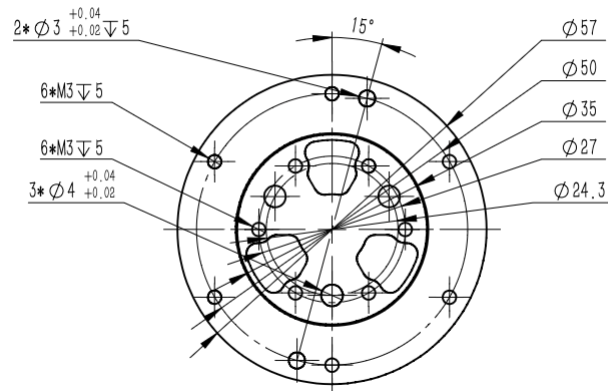
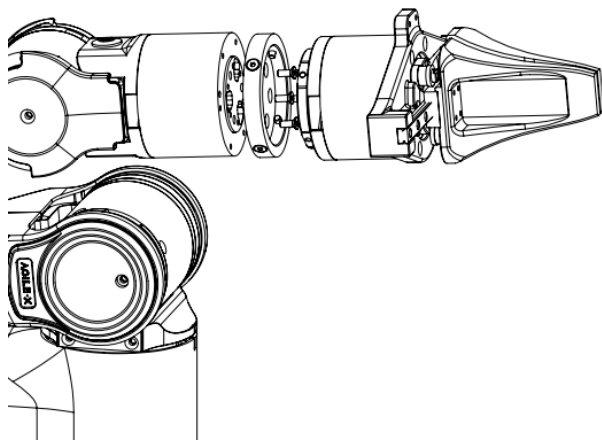

3. ArmRobotUA Host Computer Usage Instructions

Software Download:

Link:

https://www.dropbox.com/scl/fi/5vn35i6obwml0lpnmn8k8/ArmRobotUA_V1.4.5.250918_release.exe?rlkey=2zwxgvjqean25zpmxni1hgzdn&st=3t4uudf7&dl=0

Using a PC with Windows 7 or higher, double-click to open the host computer software. Through this human-machine interaction software, you can operate the robotic arm and read feedback data from the external network of the robotic arm. The user interface is shown as follows:



Host software

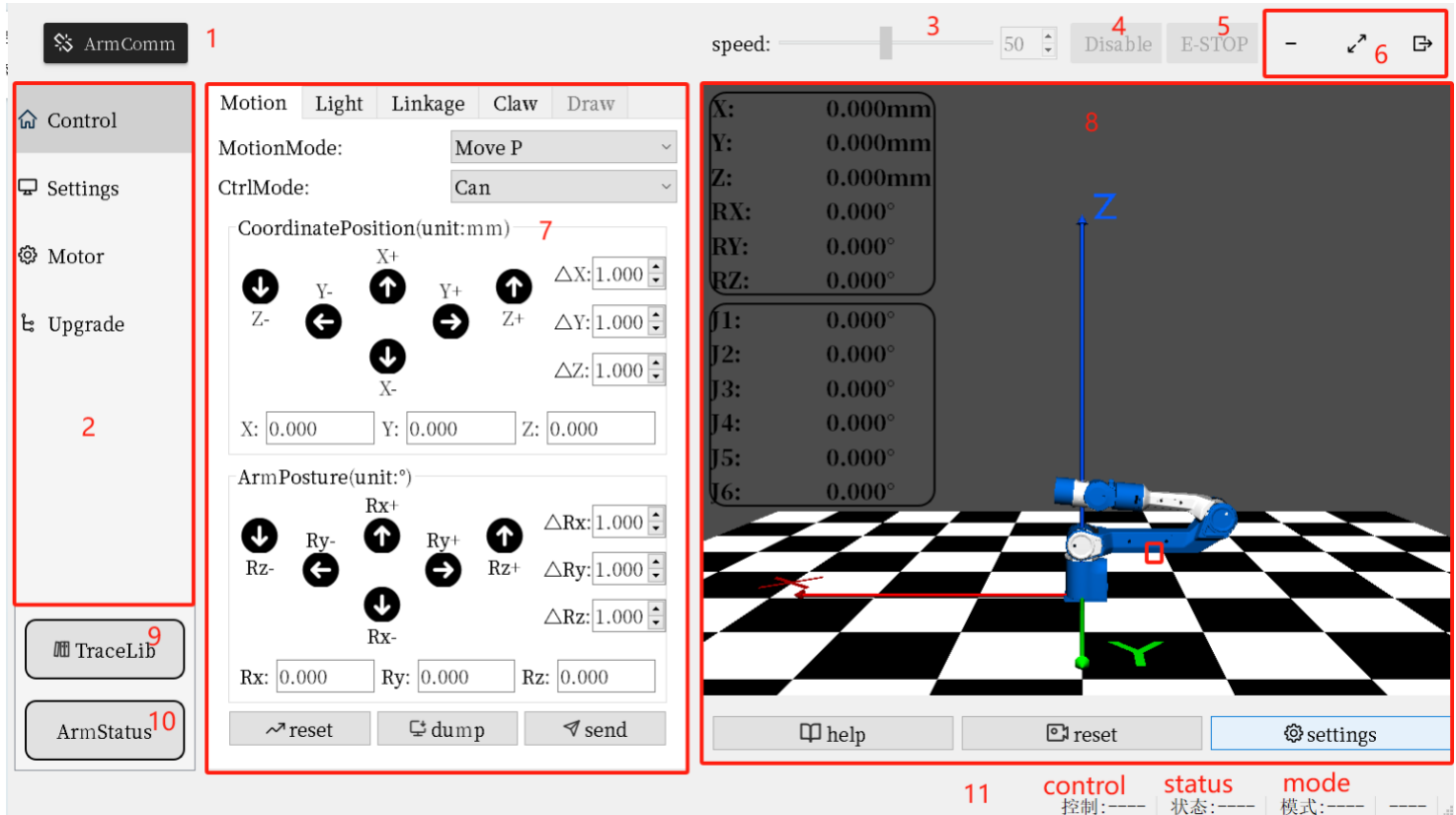

Host Computer Operation Interface

Names of the functional areas in the host computer software panel

Index	Name
1	Robotic Arm Communication Button
2	Menu Options
3	Speed Percentage Setting
4	Robotic Arm Enable Button
5	Robotic Arm Emergency Stop Button
6	Window Resize/Close Buttons
7	Operation Function Area
8	3D Simulation Model
9	Trajectory Library Function
10	Robotic Arm Joint Status
11	Robotic Arm Status Bar

4. Secondary Development

Currently, the robotic arm supports secondary development through a Python SDK and ROS1 driver package. For detailed secondary development instructions, please refer to the GitHub link.

SDK:https://github.com/agilexrobotics/piper_sdk

ROS1:https://github.com/agilexrobotics/Piper_ros/tree/ros-noetic-no-aloah

ROS2:https://github.com/agilexrobotics/Piper_ros/tree/ros-foxy-no-aloah

5. Technical Specifications

Robotic Arm Specifications:

Parameter Type	Item	Specification
Structure Parameters	Degrees of Freedom	6
	Effective Load	1.5KG
	Weight	4.2KG
	Repeatability	±0.1mm
	Working Radius	626.75mm
	Standard Power Supply Voltage	DC24V (Min: 24V, Max: 26V)
	Power Consumption	Max Power ≤ 120W, Comprehensive Power ≤ 40W
	Material	Aluminum Alloy Frame, Plastic Shell
	Controller	Integrated
	Communication Method	CAN
	Control Method	Teach by Dragging / Offline Trajectory / API / Host Computer
	External Interfaces	Power Interface x1, CAN Interface x1
	Base Installation Size	70mm x 70mm x M5 x 4
	Working Environment	Temperature: -20 to 50°C, Humidity: 25%-85%, Non-condensing
	Noise	<60dB
Installation	Compatible with all AgileX robotics products	
Motion Parameters:	Joint Motion Range	J1:±154° J2:0°~195° J3:-175°~0° J4:-106°~106° J5:-75°~75° J6:±100°
	Joint Max Speed	J1:180°/s J2:195°/s J3:180°/s J4:225°/s J5:225°/s J6:225°/s
<p>Note: The above data are test results of the AgileX robotics arm in a controlled testing environment. Results may vary under different environments and usage methods. Actual experience should be considered.</p>		

Optional follower Gripper Specifications:

Two-Finger Gripper Parameters	
Weight	500g
Accuracy	±0.5mm
Opening Distance	0-100mm
Rated Clamping Force	40N
Max Clamping Force	50N
Power Supply Voltage	DC24V
Power Consumption	Max Power ≤ 50W, Comprehensive Power ≤ 30W
Contact Surface Material	Rubber
Controller	Integrated
Communication Method	CAN
Control Method	Teach by Dragging / Offline Trajectory / API / Host Computer
External Interfaces	Power Interface x1, CAN Interface x1
Installation Method	Flange Mount
Working Environment	Temperature: -20 to 50°C, Humidity: 25%-85%, Non-condensing
Noise	<60dB
Note: The above data are test results of AgileX in a controlled testing environment. Results may vary under different environments and usage methods; actual experience should be considered.	

Optional leader gripper Specifications:

Teaching Device Parameters	
Weight	550g
Accuracy	±0.5mm
Opening Distance	0-100mm
Rated Clamping Force	40N (Force Control, Force Feedback)
Max Clamping Force	50N (Force Control, Force Feedback)
Power Supply Voltage	DC24V
Power Consumption	Max Power ≤ 50W, Comprehensive Power ≤ 30W
Contact Surface Material	Rubber
Controller	Integrated
Communication Method	CAN
Control Method	Teach by Dragging / Offline Trajectory / API / Host Computer
External Interfaces	Power Interface x1, CAN Interface x1
Installation Method	Flange Mount
Working Environment	Temperature: -20 to 50°C, Humidity: 25%-85%, Non-condensing
Noise	<60dB
Note: The above data are test results of AgileX in a controlled testing environment. Results may vary under different environments and usage methods; actual experience should be considered.	